







FLYING RAKER UP TO 4.8 M

	4/6x*	Raker Rail Pin
	4x	Swivel Base
	2/4x*	Raker Rail
	12x	Clamp
	5/7/9x*	Pull Restrictor
	2x	Swivel Base D-ring

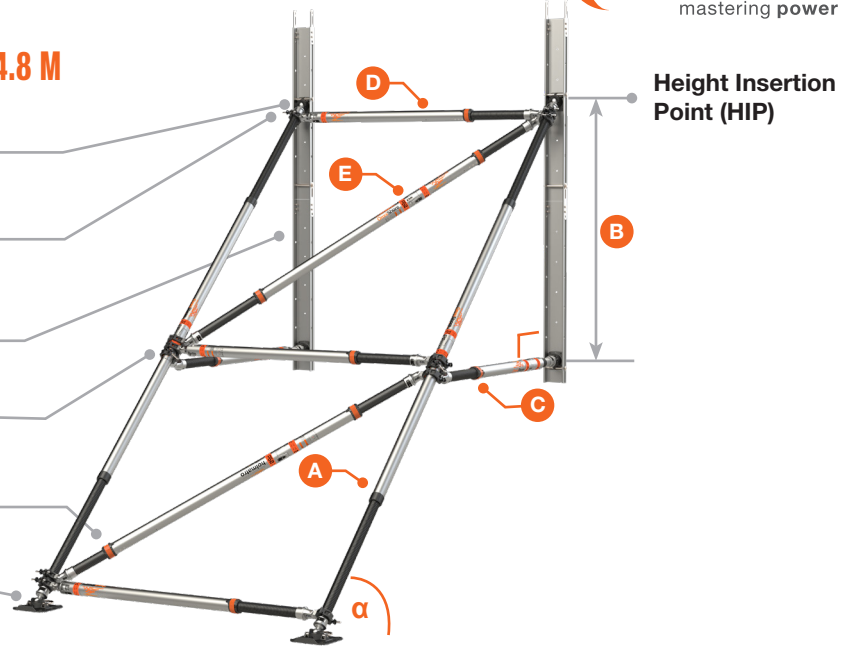

*depends on configuration

Tabulated data is based on available items within the Advanced Vehicle & Structural Shoring Set + additional Strut Bracing Set

45°	HIP	Diagonal Strut		Mid-point Brace		Horizontal Brace		Diagonal Brace	Max. Working Load	
		A	B	C		D		E	Safety Factor 2	
	cm	cm	cm	cm		cm			kg	
	388	P60+P60	519	175	P40	145	P60	162-265	depends on D	3200
	363	P60+P60	484	175	P40	145	P60	162-265	depends on D	4300
	338	P60+P60	448	125	P30	95	P60	162-265	depends on D	5500
	313	P60+P40	413	125	P30	95	P60	162-265	depends on D	6900
	288	P60+P40	378	125	P30	95	P60	162-265	depends on D	8700
	263	P60+P30	342	75	M10	45	P60	162-265	depends on D	11000
	238	P60+P30	307	75	M10	45	P60	162-265	depends on D	13800
	213	P60+P30	271	75	M10	45	P60	162-265	depends on D	17000
< 213 See tabulated data Flying Raker up to 2.5 m										

60°	HIP	Diagonal Strut		Mid-point Brace		Horizontal Brace		Diagonal Brace	Max. Working Load	
		A	B	C		D		E	Safety Factor 2	
	cm	cm	cm	cm		cm			kg	
	475	P60+P60	522	225	P30	103	P60	162-265	depends on D	2300
	463	P60+P60	508	225	P30	103	P60	162-265	depends on D	2600
	438	P60+P60	479	225	P30	103	P60	162-265	depends on D	3200
	413	P60+P60	450	225	P30	103	P60	162-265	depends on D	3900
	388	P60+P40	421	200	P30	88	P60	162-265	depends on D	4700
	363	P60+P40	392	200	P30	88	P60	162-265	depends on D	5700
	338	P60+P30	363	125	M10	45	P60	162-265	depends on D	6900
	313	P60+P30	335	125	M10	45	P60	162-265	depends on D	8300
	288	P60+P30	306	125	M10	45	P60	162-265	depends on D	10000
	263	P60+P30	277	100	M10	30	P60	162-265	depends on D	11900
< 263 See tabulated data Flying Raker up to 2.5 m										

Notes

- The shoring construction/installation must always be approved by a trained Structural Specialist.
- Distance B will determine the number of Raker Rails.
- Place a Pull Restrictor on all bracing struts C / D / E.
- Fix the Raker to the ground utilizing the large holes or the raised edge of the Swivel Base D-Ring, depending on the type of foundation.
- Fix the Raker to the wall, utilizing the holes in the Raker Rail.
- Other Raker configurations can be built if additional struts / accessories are used.

© Holmatro 2023-05-01

While the greatest care has been devoted to the content, it is possible that the information in this printed matter is incorrect or incomplete. Holmatro B.V. and its affiliated companies (hereafter: Holmatro) cannot be held liable in any way for the consequences of activities undertaken on the basis of this printed matter. Values can vary within the manufacturer measurements. If you have any doubts about the correctness or completeness of the information, you shall contact Holmatro (T +31 (0)162-751480). Nothing from this printed matter can be copied and/or made public in any way without the explicit authorization of Holmatro.

